

**SELF LOADING MOBILE  
CONCRETE MIXER  
ARGO 2000**



**ARAI CERTIFIED – CAN BE REGISTERED WITH RTO**



**TYPICAL OUTPUT : 6 to 8 cu.m/hr**

**Self-Loaders | Batching Plants | Pumps**

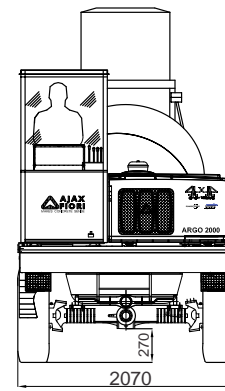
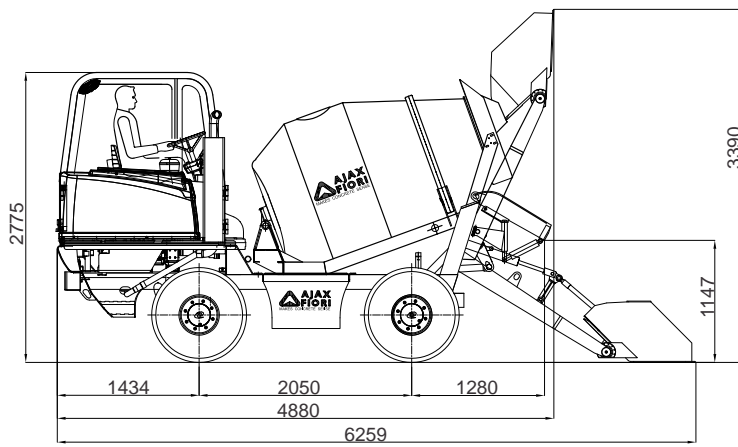

### SELF LOADING



### ERGONOMIC DESIGN



### REVERSIBLE OPERATOR POST



### TIGHT TURNING RADIUS



### HIGH GRADEABILITY



### ELECTRONIC WEIGH BATCHING



### CONCRETE BATCH CONTROLLER (OPTIONAL)



### EASE OF MAINTENANCE

**ENGINE**  
 Kirloskar 4 cylinder water cooled  
 Turbo charged Diesel engine  
 44.1 kw @ 2400 rpm  
 BS III Emission certified

**CHASSIS:**  
 High tensile steel welded "C" type  
 construction.

**TRANSMISSION:**  
 4 wheel drive, 4 Speed Automotive  
 hydrostatic transmission  
 Electro-hydraulic control for "slow" &  
 "fast" speeds.  
 Vehicle speed - 0 to 24 Km/h  
 (forward and reverse)

**BRAKE:**  
 Power braking with oil cooled disc type  
 brakes on all 4 wheels.

**STEERING:**  
 Fully powered hydraulic (orbitrol type) steering.  
 Four wheel steering for maneuvering in narrow spaces  
 Opposite wheel steering for side maneuvering

Three way steering system:

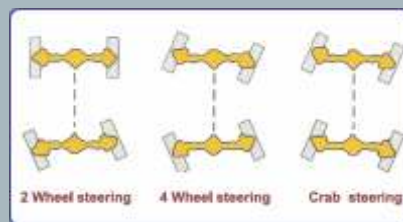

**SELF LOADING SYSTEM:**  
 Single Joy stick controlled by hydrostatic cylinders  
 operated loading shovel & 280 L bucket.

**WATER SYSTEM:**  
 230 lpm Self priming Pump and Electronic Water meter.  
 Batching from external source or from 370 L water tank.

**HYDROSTATIC DRUM DRIVE:**  
 Hydrostatic Drum Drive with high rotation  
 for homogenous mix and drum lift for fast  
 and complete discharge even on inclines.  
 Drum Volume : 2.8 cu.m  
 Concrete Output : 2 cu.m  
 Maximum Drum Rotation : 0 - 18 rpm

**ELECTRONIC WEIGH BATCHING :**  
 Up to 8 different aggregates can be weighed  
 & batched in "addition" or subtraction" mode.

**WHEELS :**  
 Tyre : 12.0 / 75-18-12 PR  
 Rim Size : 9.0" x 18.0"

**WEIGHT:**  
 Net vehicle weight : 4790 kgs  
 Gross vehicle weight : 9590 kgs

Specifications are subject to change without prior notice



### AJAX FIORI ENGINEERING (INDIA) PRIVATE LIMITED

#253/1, 11th Main, 3rd Phase, Peenya Industrial Area, Bangalore-560058, INDIA  
 CIN No : U28920KA1992PTC013306  
 T : 91 80 6720 0082, 6720 0083, F: 91 80 6720 0031  
 Email : contact@ajax-fiori.com, Website: www.ajax-fiori.com

For Sales Queries :

Northern Region : 096500 36628  
 Eastern Region : 094331 44581

Western Region : 099672 63628  
 Southern Region : 098450 58628

Central Region : 09893040760

Factory: 3, 16 & 17, KIADB Industrial Area, Bashettihalli Doddaballapur - 561 203, Karnataka, India, T : +91 80 6720 1135